

## D. PUSHCART VENDING

### DESIGN STRATEGY

**Pushcart** vendors enliven the pedestrian environment by providing convenience and a diversity of products at affordable prices. Pushcarts lend charm, vitality, and diversity to an active urban environment.

### APPLICATION PROCESS

Applications for pushcart vending permits are obtained from the Downtown Permits Office. Each permit application must include the following items:

1. A Home Occupation Use Permit for home-based businesses (contact 516-2550 for more information).
2. A Food Vending Permit from the Wake County Environmental Services Department to ensure that the Local, State and Federal sanitary and health regulations are met (contact 856-7400 for more information).
3. A valid Business License from the City of Raleigh. Established businesses requesting permits may produce a copy of the active Business License and Proof of Insurance.
4. A scaled sketch plan and photographs showing proposed cart location, dimensions, and details of surrounding streetscape elements, covering 6 feet on all sides of the edge of the proposed **cart operation area** including property lines, sidewalks, curb lines, lighting, trees indicating tree size, tree grates, planters, parking meters, benches, street signs, bus stops, and fire hydrants.
5. A list of products to be offered for sale.
6. Proof of a valid Insurance Policy that provides a minimum liability of one million dollars. The City of Raleigh must be additionally insured under the policy.
7. A written Indemnity Agreement satisfactory to the City Attorney that will hold harmless the City, its officers, councilors and employees, for any loss or liability or damage, including expenses and costs, for bodily or personal injury, and for property damage sustained by an person as a result of the negligent installation, use, or maintenance of a permitted public space within the City of Raleigh (see Appendix Section 5 for sample Indemnity Agreement).
8. Fee payment (see table below).
9. A Food Permit from the NC Department of Agriculture for those wishing to sell baked goods or ice cream (contact 733-7366 for more information).

**Please Note:** After acquiring the City permit, applicants are urged to get a NC Sales and Use Tax certificate from the State. Please contact 1-877-252-3052 for more information.

### REQUIRED PERMITS

- Home Occupation Use Permit (*for home-based businesses*)
- Wake County Environmental Services- Vending Permit (*for food vendors only*)
- City of Raleigh Business License
- Pushcart Vending Permit
- NC State Agriculture Department- Food Vending Permit (*for baked goods and ice cream vending only*)

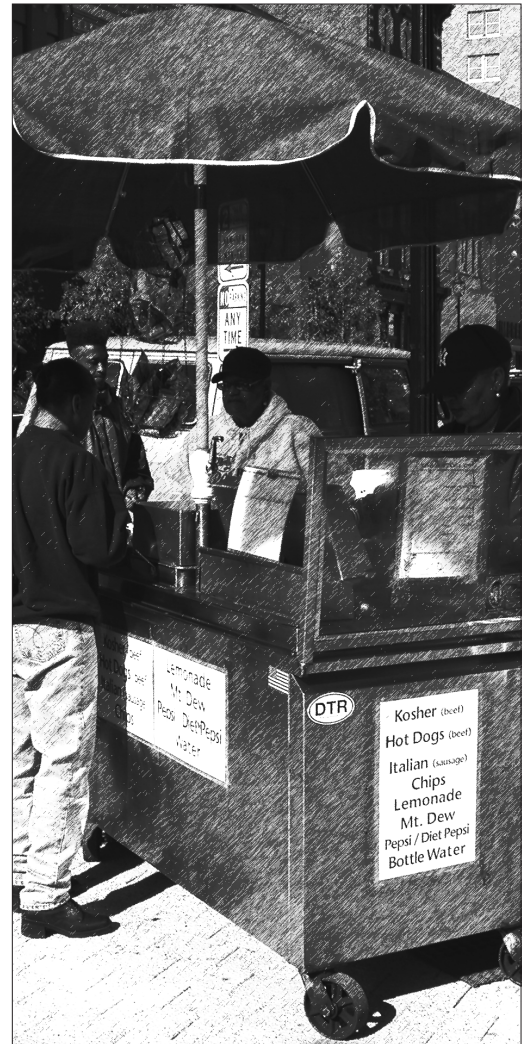

## FEE SCHEDULE

Item	Fee
Home Occupation Use Permit	\$70
Wake County Environmental Services Approval Letter	Varies*
City of Raleigh Business License	\$25
Pushcart Vending Permit	\$60
NC State Agriculture Department- Food Vending Permit (for baked goods and ice cream vending)	Varies*

\* Fee varies with nature, type and size of business

## PERMIT PROVISIONS

- Pushcart Vending permits are valid for one year (from July 1st through June 30th).
- All permit renewal applications and Business License renewal applications must be submitted by June 30th to the Downtown Permits Office.
- If at any time, the Wake County Environmental Services revokes or suspends the issued food vending permit, the City permit is revoked or suspended simultaneously.
- At the time of annual permit renewal, the DPO will determine whether any business located within 50 feet of the proposed vending location is of a competing nature. Upon determining the competing status of the proposed vending location, applicant will be required to choose an alternative location for vending purposes.
- At the time of submittal of permit applications, applicants are also encouraged to provide contact email addresses that will be added to a list serve created for permit holders. Downtown Permits Office maintains record of all permits including contact information.
- Downtown Permits Office notifies applicants regarding the status of their permit approval.
- The permit holder is liable for all damages and repairs to the streetscape, trees and vegetation, sidewalks, streets, or other public amenities that directly relate to the use of the permitted space.
- Permit holders may be required to remove private materials or accessories temporarily to allow street, sidewalk, or utility access for maintenance operations or during approved special events. The Downtown Raleigh Alliance notifies permit holders via email at least 24 hours in advance of event related street closures approved through City Council.
- Special event permits supersede annual permits. During a special event approved by the City, annual permits are temporarily suspended. Carts are excluded within 400 feet of the edge of any special events area unless the annual permit holder is granted written permission from the event sponsor/ coordinator to set up within the designated event area. The permit holder is responsible for keeping track of upcoming special events and the designated boundaries that may affect their business. For more details on Downtown Special Events, please contact the Downtown Raleigh Alliance at 832-1231. All latest information on Downtown events can be tracked at the following website: <http://www.godowntownraleigh.com/>
- Permits for qualifying locations that are available are allocated on a first-come, first-served basis. The time of submittal of the complete application, as validated by the permits officer will be stamped and recorded. For multiple requests received for one qualifying location, a lottery will be executed for assigning the spot. All permits will be issued after a site inspection is completed by the Zoning Department Inspection Officer.
- All issued permits are location-specific. If, within a given year of receiving permit, the applicant desires to change location of business, the application and the applicable fees will have to be submitted for the new location. All permits will be issued after a site inspection is completed by the Zoning Department Inspection Officer.
- Details regarding appeals are provided in Section I.D.3 of this handbook.
- For all pushcart permits issued prior to January 1, 2008, the first two permit holders who were issued the permits will be qualified to retain the two eligible vending spots along a block face. Remaining vendors who have been permitted along the relevant block will be reassigned to other available locations of Downtown.

**Violations**

- The City of Raleigh Inspections Department notifies permit holders of violations.
- The permit holder is responsible for remedying the violation within the time period specified in the notice. Beyond that, fines or subsequent revocation of permits applies as per the standard procedure outlined in Section I.D.3 of this handbook.
- Permit violations incur a first time fine of \$100. Subsequent violations are \$200 for each occurrence and permits are revoked if a third violation occurs within a fiscal year.

**STANDARDS**

For pushcart vending to be permitted within downtown public spaces, all of the following standards must be met.

**Location**

- Carts must not locate in any location that impedes, endangers, or interferes with pedestrian or vehicular traffic.
- All carts must operate in locations that are deemed **non-competing** to fixed-location businesses at a minimum of 50 feet away from a fixed establishment selling similar products excluding beverages. However, with the written permission from the fixed establishment, vendors can locate within 50 feet of such an establishment and sell similar products.
- Vending carts are excluded in public areas that are:
  - within construction areas,
  - within 400 feet of the boundary of any special events area without the granted written permission from the event sponsor/ coordinator, or
  - within a 5 foot radius of any building corner adjacent to a street intersection.
- A maximum of two cart operation areas are permitted per block. Cart operation areas must be at minimum 5 feet apart when each sell different primary products, and at minimum 100 feet apart when each sell the same primary products. PLEASE NOTE: For all pushcart permits issued prior to January 1, 2008, the first two permit holders who were issued the permits will be qualified to retain the two eligible vending spots along a block.
- Cart operation areas must not include the landscaped areas between the sidewalk and edge of curb.
- Carts must not be locked or attached to trees.
- Food carts are not permitted to operate within 50 feet of an outdoor dining space along a street block face. However, with the written permission from the restaurant owner providing the outdoor dining services, vendors can locate within 50 feet of the pertaining outdoor dining area.
- Carts must be located at least 5 feet from the edge of any driveway, edge of a crosswalk, utility boxes and vaults, handicapped ramp, building entrances, exits or emergency access/ exit ways, or emergency call box.
- An unobstructed sidewalk pedestrian corridor of a minimum of 5 feet in width must be maintained parallel to the street at all times. Where existing obstructions are present (such as fire hydrants), the corridor is measured to go around these obstructions. For tree grates, the corridor is measured from the outer edge of the grate, unless an ADA-compliant grate is installed, in which case the 5 feet can be measured directly from the tree trunk.

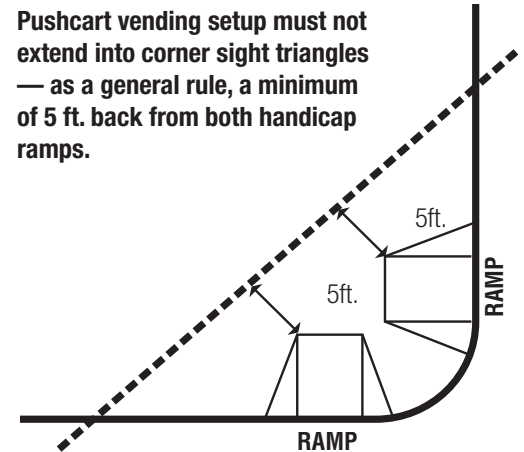

**Pushcart vending setup must not extend into corner sight triangles — as a general rule, a minimum of 5 ft. back from both handicap ramps.**

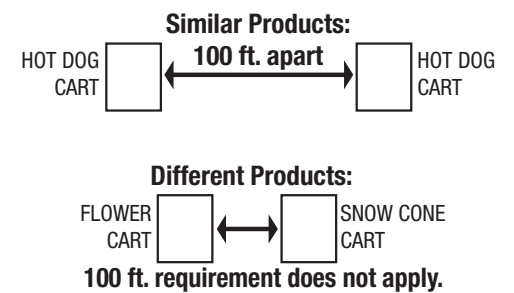

**Clear space requirements around tree grates and other obstructions.**

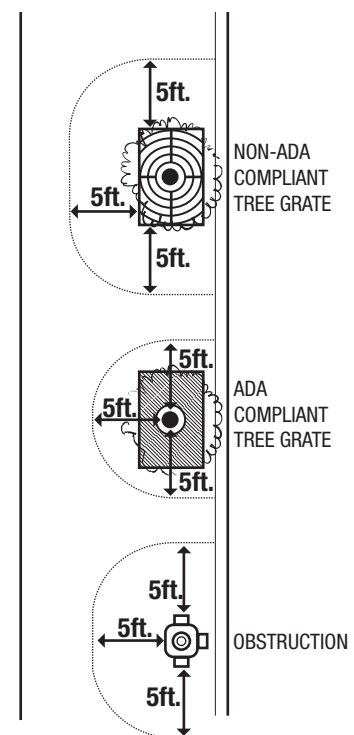



### Fayetteville Street Location Standards

- An unobstructed pedestrian space a minimum of five feet must be maintained around the cart. NOTE: All carts permitted prior to January 1, 2008 are grandfathered against this requirement. Where existing obstructions are present (such as fire hydrants), the corridor can be measured to go around these obstructions. For tree grates, the corridor is measured from the outer edge of the grate, unless an ADA-compliant grate is installed, in which case the 5 feet can be measured directly from the tree trunk.
- An unobstructed pedestrian corridor a minimum of 7 feet in width must be maintained parallel to the street at all times.

### Design

- All carts must be non-motorized with operable wheels. Persons with disabilities are permitted to use a motorized system to propel the pushcart.
- All food vending carts should be equipped with an appropriate grease blanket/guard to trap grease from dripping onto public space.
- All carts must be self-contained with a waste receptacle. All equipment required for the operation (exceptions apply to food vendors for use of coolers), must be contained within the cart. Vendors must not empty waste into City-owned trash receptacles.
- Cart dimensions must not exceed 6 feet H. x 8-1/2 feet L. x 4 feet W.; total **cart operation area** must not exceed 100 square feet. Carts permitted prior to January 1, 2008 are grandfathered against the 6-foot maximum height requirement.
- Cart umbrellas or canopies must be attached to the cart, and must not exceed 8 feet in height (above grade). Maximum umbrella diameter must not exceed 6 feet. Canopies must not extend more than 2 feet in any direction beyond the width and length of the cart. Umbrellas and canopies must not interfere with tree canopy, signage, or free movement of pedestrians.
- Carts are limited to 2 umbrellas each.
- Vendor pushcarts must be made of durable material and no plastic, unfinished, or pressure treated wood may be visible. All materials must be in accordance with all Local, State, Federal and Wake County Environmental Services rules and regulations.
- Pushcarts must be covered with an appropriate material to prevent exposure of food products to wind, dust, and insects and be in compliance with all applicable Local, State and Federal Health Department sanitary regulations. A copy of the *State Rules Governing the Sanitation of Food Service Establishment* (15 A NCAC 18A .2638-40) can be obtained at the link: <http://www.deh.enr.state.nc.us/ehs/rules/t15a-18a.26.pdf>
- Pushcarts and umbrellas must incorporate professional self-contained signage and meet other sign regulations in place (Refer to Sec. 12-1001 of the City Code for sign regulations). Total signage on carts must not exceed 24 square feet.
- No free-standing signage is permitted as part of the pushcart vending operation.

### Operation

- Sales of goods and **merchandise** are limited to food and beverage items, fresh cut flowers, original artwork, and **handicrafts** produced by the **vendor/artisan**.
- All items being offered for sale must be confined to the cart.
- Food vendors are allowed to place a maximum of 3 coolers (a maximum capacity of 80 quarts) on the public space within the cart operation area. Coolers must be

stored and stacked in such a manner so as not to create visual clutter.

- All accessories used for the operation of food vending carts must be placed within 3 feet of the outer edges of the cart.
- Pushcart vendors are limited to the use of one stool/ chair for seating purposes within the cart operation area. No seating is allowed for patrons.
- Pushcarts must not be stored, parked, or left overnight on any street, sidewalk, or in any parking space of the city.
- Hours of operation of vending carts are limited to the hours between 6:00 a.m. and 4:00 a.m.
- Carts must be removed from the location between 4:00 a.m. and 6 a.m.
- Pushcart operator or his/her designee must be present at the pushcart at all times except in cases of an emergency.
- Permits are not transferable or assignable.
- The waste water disposal standards of the Local and State sanitary regulations must be met for the cart operation. A copy of the State *Rules Governing the Sanitation of Food Service Establishment* (15 A NCAC 18A .2638-40) can be obtained at the link: <http://www.deh.enr.state.nc.us/ehs/rules/t15a-18a.26.pdf>
- If at any time, the Wake County Environmental Services revokes or suspends the issued food vending permit, the City permit is revoked or suspended simultaneously.
- Permits assigned to locations that are left vacant for more than 3 months after permit issuance will be revoked. The permit holders will have to reapply for permits thereafter. Permits for the revoked location will be issued on a first-come, first-served basis. The time of submittal of the complete application, as validated by the permits officer will be stamped and recorded. For multiple requests received for this location, a lottery will be executed for assigning the spot. NOTE: Locations that are affected by construction work or other, permitted temporary obstructions will be exempted.

### **Maintenance**

- The pushcart vendor is responsible for the proper disposal of waste and trash associated with the operation. City trash receptacles are not to be used for this purpose. Vendors shall remove all waste and trash from their approved location at the end of each day or as needed to maintain the health and safety of the public. The vendor must keep clean all areas within 5 feet of the cart operation area clean of grease, trash, paper, cups, coolers, or cans associated with the vending operation.
- No liquid waste or grease is to be disposed in tree pits, storm drains, or onto the sidewalks, streets, or other public space. The vendor is responsible for the removal of grease from sidewalk and street surfaces resulting from the daily operation, unloading, and loading of the pushcart.

### **CHECKLIST**

- Home Occupation Use Permit (*for home-based businesses*)
- Wake County Environmental Services- Vending permit (*for food vendors only*)
- City of Raleigh Business License
- Completed Pushcart Vending Application
- Annual Fees
- Proof of Insurance
- Indemnity Agreement
- NC State Agriculture Department- Food Vending Permit (*for baked goods and ice cream vending only*)

*Downtown Overlay District*

**PUSHCART VENDING: Location Parameters**

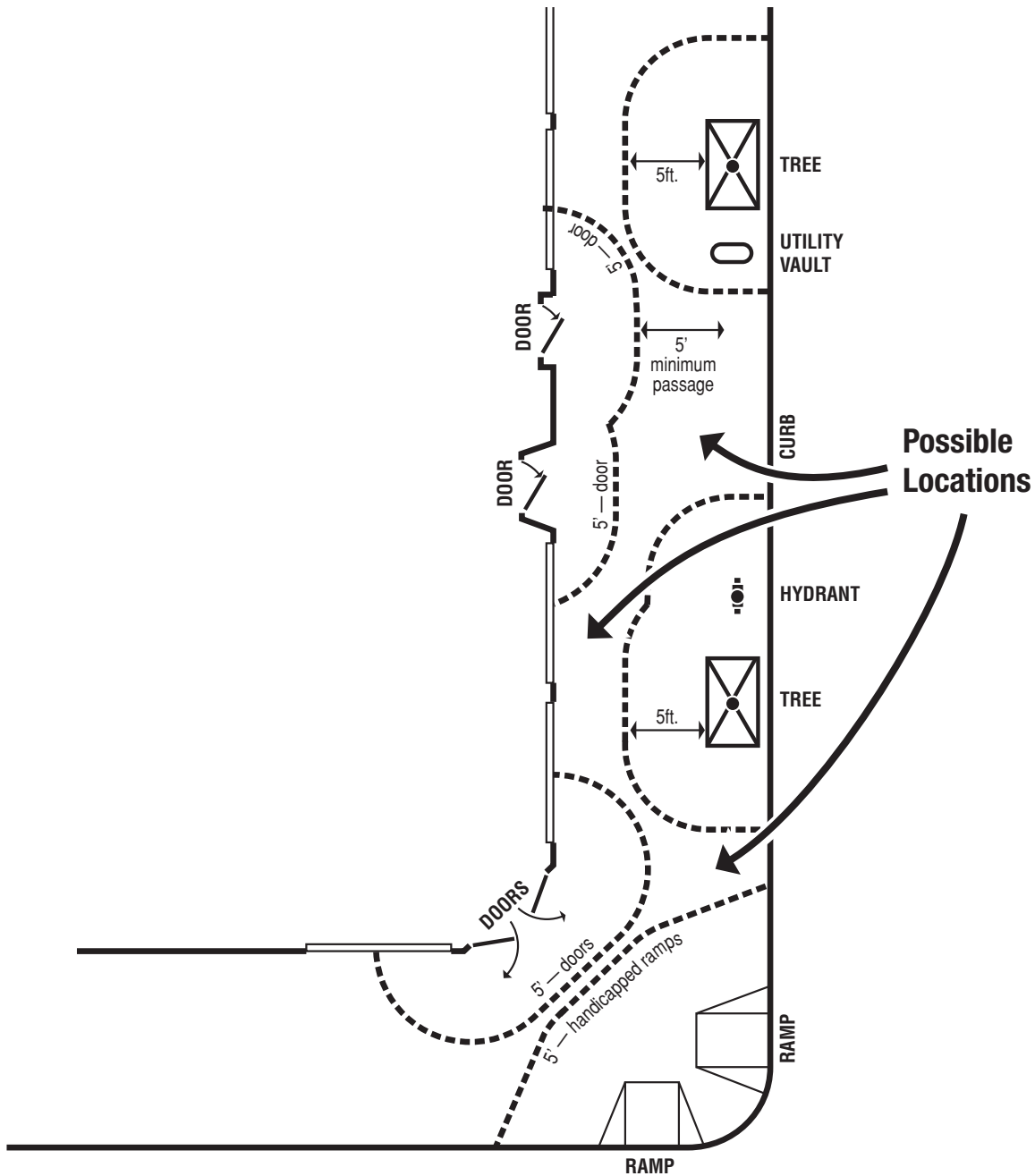

*Downtown Overlay District*

**PUSH CART VENDING: Design and Operation Parameters**

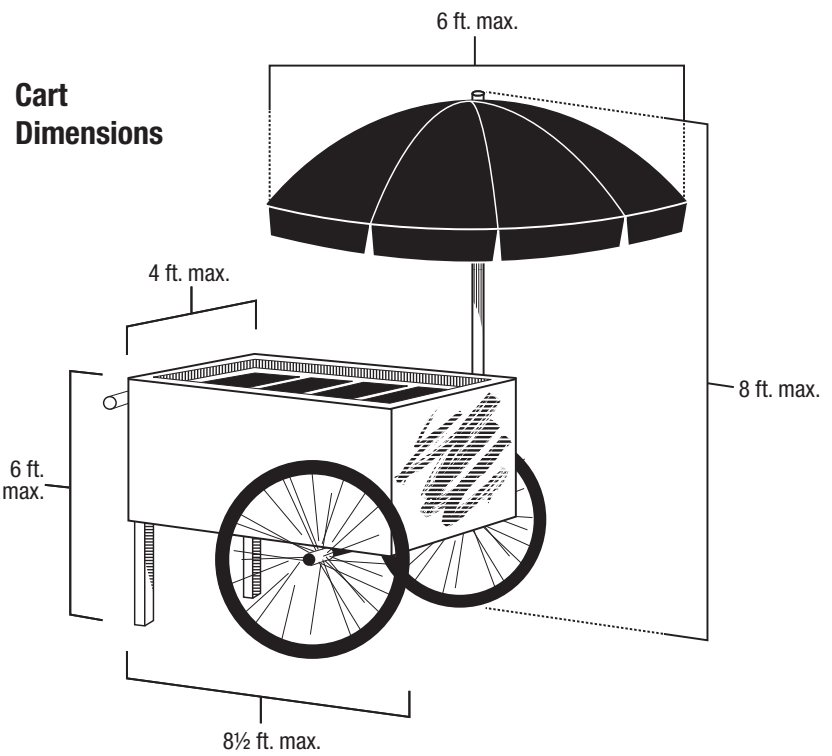

**Space Requirements**

