

# Design Adjustment Application



**DEVELOPMENT SERVICES DEPARTMENT**

The purpose of this request is to seek a Design Adjustment from the Development Services Director, or designee, for a specific project only and, if granted, may be approved with special conditions and provisions. This application and all further action shall be consistent with Section 10.2.18 in the Unified Development Ordinance (UDO). The consideration and decision of this request shall be based solely on the conformance of the findings, as outlined in Sec. 8.3.6, Sec. 8.4.1.E and Sec. 8.5.1.G of the UDO or the Raleigh Street Design Manual.

<b>PROJECT</b>	<b>Project Name</b> 611 W South St Condos		
	<b>Case Number</b> SR-48-18		
	<b>Transaction Number</b> 555667		
<b>OWNER</b>	<b>Name</b> Lambert Development South Street LLC		
	<b>Address</b> 5 Hanover Sq Floor 14		<b>City</b> New York
	<b>State</b> NY	<b>Zip Code</b> 10004-2614	<b>Phone</b> 212-785-0090 x225
<b>CONTACT</b>	<b>Name</b> Rob Caudle		<b>Firm</b> WithersRavenel
	<b>Address</b> 137 S. Wilmington St. Suite 200		<b>City</b> Raleigh
	<b>State</b> NC	<b>Zip Code</b> 27601	<b>Phone</b> 919-238-0359
<b>REQUEST</b>	<b>I am seeking a Design Adjustment from the requirements set forth in the following:</b>		
	<input type="checkbox"/> <a href="#">UDO Art. 8.3 Blocks, Lots, Access</a>	- See page 2 for findings	
	<input type="checkbox"/> <a href="#">UDO Art. 8.4 New Streets</a>	- See page 3 for findings	
	<input type="checkbox"/> <a href="#">UDO Art. 8.5 Existing Streets</a>	- See page 4 for findings	
	<input checked="" type="checkbox"/> <a href="#">Raleigh Street Design Manual</a>	- See page 5 for findings	
<b>Provide details about the request; (please attach a memorandum if additional space is needed):</b>			
This is a request to provide 4' x 6' street tree planters in place of the 4' x 6' street tree grates that are specified in the Raleigh Street Design Manual			

It is the responsibility of the applicant to provide all pertinent information needed for the consideration of this request. Applicant must be the Property Owner.

By signing this document, I hereby acknowledge the information on this application is, to my knowledge, accurate.

*[Signature]*  
Owner/Owner's Representative Signature

*manager*

*Sept 6 2018*  
Date

## CHECKLIST

Signed Design Adjustment Application	<input checked="" type="checkbox"/> Included
Page(s) addressing required findings	<input checked="" type="checkbox"/> Included
Plan(s) and support documentation	<input checked="" type="checkbox"/> Included
Notary page (page 6) filled out; Must be signed by property owner	<input checked="" type="checkbox"/> Included
First Class stamped and addressed envelopes with completed notification letter	<input checked="" type="checkbox"/> Included

Submit all documentation, with the exception of the required addressed envelopes and letters to [designadjustments@raleighnc.gov](mailto:designadjustments@raleighnc.gov).

Deliver the addressed envelopes and letters to:  
Development Services, Development Engineering  
One Exchange Plaza, Suite 500  
Raleigh NC, 27601

<b>For Office Use Only</b>	<b>RECEIVED DATE:</b>	<b>DA -</b>	-
----------------------------	-----------------------	-------------	---



---

The Development Services Director may in accordance with *Sec. 10.2.18*, approve a design adjustment, subject to all of the following findings. Describe how each item is met:

- A. The requested design adjustment meets the intent of the Raleigh Street Design Manual;

**The proposed 4' x 6' street tree planters will accommodate growth better than the typical 4' x 6' street tree grates. The proposed street tree planters are consistent with the cross-sectional dimensions specified in the Street Type Overview section of the Raleigh Street Design Manual.**

- B. The requested design adjustment conforms with the Comprehensive Plan and adopted City plans;

**The proposed street tree planters will have no affect on the Comprehensive Plan and adopted City plans.**

- C. The requested design adjustment does not increase congestion or compromise safety;

**There will be a 10' clearance behind the proposed street tree planters.**

- D. The requested design adjustment does not create additional maintenance responsibilities for the City; and

**The proposed street tree planters eliminates cost and maintenance responsibilities of metal grates. No additional maintenance responsibilities will be required.**

- E. The requested design adjustment has been designed and certified by a Professional Engineer.

**A Professional Engineer has designed and certified the requested design adjustment (see plans).**

# Individual Acknowledgement



DEVELOPMENT  
SERVICES  
DEPARTMENT

STATE OF NORTH CAROLINA

INDIVIDUAL

COUNTY OF WAKE

I, MELISSA S. BOEHL, a Notary Public do hereby certify that  
HENRY LAMBERT personally appeared before me this day and  
acknowledged the due execution of the forgoing instrument.

This the 6<sup>th</sup> day of September, 2018.



Notary Public Melissa S Boehl

My Commission Expires: 6/13/23

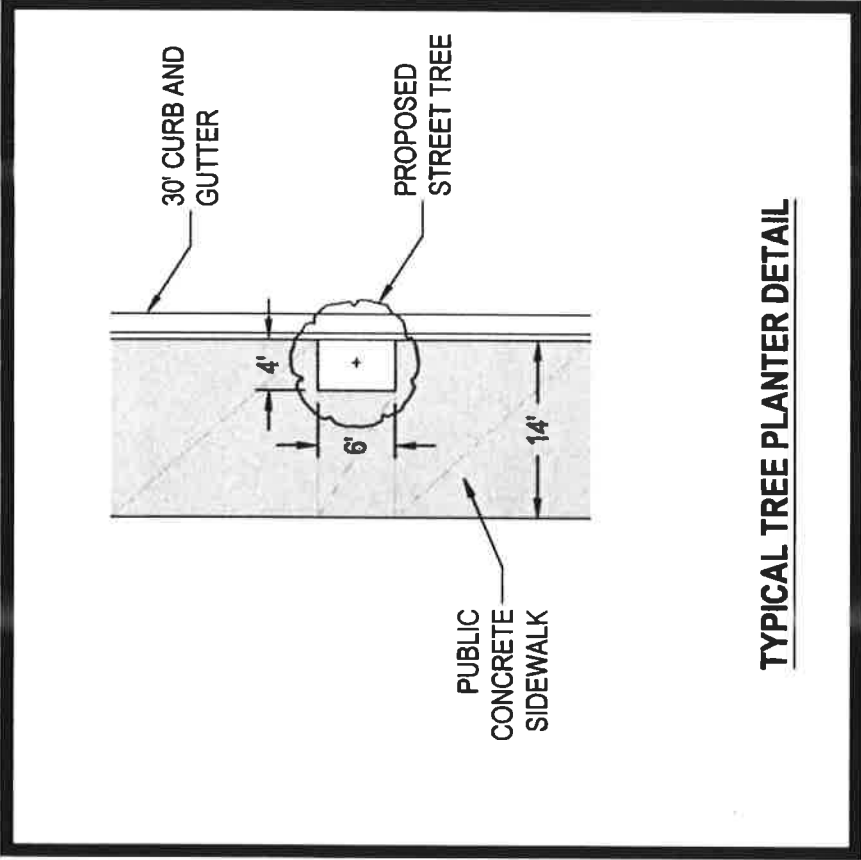

8/14/18

PROFESSIONAL SEAL  
 ENGINEER  
 ROBERT CAUDLE  
 043137